

ICC-ES Evaluation Report

ESR-1911

Reissued September 1, 2010

This report is subject to renewal in two years.www.icc-es.org | (800) 423-6587 | (562) 699-0543

A Subsidiary of the International Code Council®

DIVISION: 03 00 00—CONCRETE**Section: 03 11 19—Insulating Concrete Forming****REPORT HOLDER:****BUILDBLOCK BUILDING SYSTEMS, LLC**
9705 NORTH BROADWAY EXT., SUITE. 200
OKLAHOMA CITY, OKLAHOMA 73114
(405) 840-3386
www.buildblock.com**EVALUATION SUBJECT:****BUILDBLOCK® INSULATING CONCRETE FORMS (ICFs)****1.0 EVALUATION SCOPE****Compliance with the following codes:**

- 2006 *International Building Code*® (IBC)
- 2006 *International Residential Code*® (IRC)
- BOCA® *National Building Code*/1999 (BNBC)
- 1999 *Standard Building Code*® (SBC)
- 1997 *Uniform Building Code*™ (UBC)

Properties evaluated:

- Structural
- Surface-burning characteristics
- Crawl space fire evaluation
- Fire-resistance-rated construction
- Noncombustible construction

2.0 USES

BuildBlock® Insulating Concrete Forms (ICFs) are used as stay-in-place formwork for structural concrete, load-bearing and nonload-bearing, below-grade and above-grade walls. The forms are used in construction of plain and reinforced concrete beams, lintels, exterior and interior walls and foundation and retaining walls. The forms remain in place after placement and curing of concrete and must be covered with approved interior and exterior finish material, except for crawl space installations in accordance with Section 4.4.2. The forms are recognized for use in buildings of noncombustible construction when installed in accordance with Section 4.10.

3.0 DESCRIPTION**3.1 General:**

The ICFs consist of two expanded polystyrene (EPS) foam plastic panels separated by injection-molded polypropylene cross-ties which are partially embedded into the EPS panels. The polypropylene cross-ties maintain the EPS

panel facings at a fixed clear distance of 4 inches (102 mm), 6 inches (152 mm) or 8 inches (203 mm) to create overall form widths of 9 inches (229 mm), 11 inches (279 mm) or 13 inches (330 mm). The form units have a preformed interlocking mechanism along the top and bottom edges, to facilitate interlocking and stacking. In addition to the standard forms, 45-degree angle corners, 90-degree angle corners and ledge forms used to construct corbels that serve as ledgers to support exterior brick veneers are available. The forms are classified as a flat ICF wall system in accordance with IRC Section R611.3. See Figures 1 through 4 for illustrations of the forms.

3.2 Material:

3.2.1 Panels: The EPS panels are 16 inches (406 mm) high, 48 inches (1219 mm) long and 2½ inches (64 mm) thick. The panels are manufactured by injecting and expanding polystyrene beads into molds. The resulting EPS foam plastic complies with ASTM C 578 as Type II, with a nominal density of 1.5 pcf (24.1 kg/m³). The EPS foam plastic has a flame-spread index of 25 or less and a smoke-developed index of 450 or less when tested in accordance with ASTM E 84 (UBC Standard 8-1).

3.2.2 Polypropylene Cross-tie: The polypropylene cross-ties, spaced 6 inches (152 mm) on center, connects the EPS foam plastic panels at a fixed clear distance. The cross-tie consists of a flange portion that is embedded in the foam plastic panel during the foam plastic molding process, and a web portion that connects the two flanges and therefore the two foam plastic panels. The cross-tie has openings to permit concrete to flow through, and has slots to support horizontal steel reinforcing bars. The plastic flange of the cross-tie is recessed ½ inch (12.7 mm) below the EPS surface and is used for attachment of exterior and interior finish materials. The flange of the cross-tie is 1½ inches wide by 15 inches high by 3/16 inch thick (38 mm by 381 mm by 4.8 mm). The cross-tie also includes a web hard point area which is denoted by a "BB" on the ICF and consists of as a double reinforced section of the flange that is spaced 8 inches (203 mm) on center vertically and 6 inches (152 mm) on center horizontally.

3.2.3 Concrete: Concrete must be normal-weight concrete complying with the applicable code, and must have a maximum aggregate size of ¾ inch (19.1 mm) and a minimum specified compressive strength of 2,500 psi (17 MPa) at 28 days, except as noted in Table 1 for fire-resistance-rated assemblies. Under the IRC, concrete must comply with IRC Sections R404.4.6 and R611.6.2; under the SBC, concrete must comply with SBC Section 1916.6.1.

3.2.4 Reinforcement: The reinforced walls must be reinforced with deformed steel bars having a minimum specified yield stress of either 40 ksi (276 MPa) or 60 ksi (413 MPa), depending on the structural design. The deformed steel bars must comply with Section 3.5.3.1 of ACI 318. If construction is based on the IRC or SBC, reinforcement must comply with IRC Sections R404.4.6 and R611.6.2 or SBC Section 1916.6.2, respectively.

3.2.5 Window and Door Framing: Wood members in contact with concrete for plates of window and door framing must be naturally durable wood or treated with an approved wood preservative and attached with hot-dipped galvanized or stainless steel fasteners in accordance with the applicable code. Materials other than wood, such as vinyl or metal, are permitted for window and door framing if approved by the code official.

4.0 DESIGN AND INSTALLATION

4.1 General:

Design and installation of ICFs must comply with this report, the applicable code and the manufacturer's published installation instructions. The manufacturer's published installation instructions must be available at the jobsite at all times during installation.

4.2 Design:

4.2.1 IBC, UBC or BNBC Method: Concrete walls formed by the ICFs must be designed and constructed in accordance with IBC, UBC or BNBC Chapters 16 and 19, as applicable. Footings and foundations must be designed and constructed in accordance with IBC, UBC or BNBC Chapter 18, as applicable.

4.2.2 Alternative UBC Design Method: For walls limited to a maximum of two stories plus a basement, and a maximum unsupported wall span of 10 feet (3048 mm), walls may be designed in accordance with Publication No. EB118, Prescriptive Method for Insulating Concrete Forms in Residential Construction, dated May 1998, published by the Portland Cement Association, subject to all applicability limits in Table 1.1 of that document.

4.2.3 IRC, IOTFDC or SBC Method: Insulated concrete walls must comply with IRC Figure R611.3 and SBC Figure 1916.3 as flat insulating concrete wall forms. Wall design, construction and materials must comply with IRC Sections R404.4 and R611, or IOTFDC Section 404.1 and Tables 404.1.1(1) and 404.1.1(2), or SBC Sections 1804.6.2 and 1916, as applicable, for flat ICF wall systems. The 4-inch (102 mm) walls are limited to above-grade construction in accordance with Section R611 of the IRC.

4.2.4 Alternative IRC, or SBC Design Method: When BuildBlock® ICFs are used to construct buildings that do not conform to the applicability limits of IRC Sections R404.4.1 and R611.2 or SBC Sections 1916.2 and 1804.6.2.1 the structural analysis and design of the concrete must be in accordance with ACI 318 and Chapter 19 of the IBC, BNBC, SBC or UBC, as applicable.

4.3 Installation:

The ICFs and resulting concrete walls must be supported on concrete footings and foundations complying with IBC or UBC Chapters 18 and 19, the IRC or IOTFDC Chapter 4, or BNBC or SBC Chapter 18, as applicable. Placement of the form units must begin at a corner and proceed around the building perimeter. The amount, placement and spacing of reinforcing required must be determined for each project, based on the approved plans and the applicable code. Vertical rebar embedded in the footing

must extend into the base of the wall system the minimum development length necessary for compliance with Chapter 12 of ACI 318 or IRC Section 611.7.1.2, or UBC Section 912, as applicable. Additional reinforcement around doors and windows must be described in the approved plans. Concrete quality, mixing and placement must comply with the applicable code. Window and door openings must be built into the form units, prior to the placement of the concrete, with wood, steel bucks or polyvinyl chloride plastic frames of the same dimensions as the "rough stud opening" specified by the window or door manufacturer. Wood ledgers must be attached to the concrete wall by removing the face shell of the form units, with the height of the removed portion being equal to the depth of the wood ledger. Wood plates must be anchored to the top of the concrete wall. Anchor bolts used to connect the wood ledgers, plates and framing for wall openings to the concrete must be cast in place, with the bolts sized and spaced, as required by the design and the applicable code. Details must be prepared to accommodate the specific job situation, in accordance with the applicable code and the requirements of this report, subject to the approval of the code official.

4.4 Interior Finish:

4.4.1 General: Form units exposed to the building interior must be finished with an approved 15-minute thermal barrier, such as minimum 1/2-inch-thick (12.7 mm) gypsum wall board complying with ASTM C 36, placed with the long side vertical. The gypsum wall board must be attached to web-tie flanges with 1 5/8-inch-long (41mm), No. 6, Type W, coarse-thread gypsum wall board screws spaced 16 inches (406 mm) on center vertically and 12 inches (305 mm) on center horizontally. The screws must penetrate a minimum of 1/4 inch (6.4 mm) through the web-tie flange. Gypsum wall board joints must be taped and finished with joint compound in accordance with ASTM C 840 or GA 216. See Section 4.4.2 for installation details for crawl space applications without an ignition barrier on the interior face.

4.4.2 Attic and Crawl Space Installations: When the BuildBlock® ICFs described in this report are used as walls of crawl spaces and no ignition barrier is applied to the attic or crawl space side of the foam plastic, all of the following conditions must be met:

- Entry to the crawl space is only to service utilities, and no storage is permitted.
- There are no interconnected attic or basement areas.
- Air in the attic or crawl space is not circulated to other parts of the building.
- Under-floor (crawl space) ventilation is provided that complies with IBC Section 1203.3, IRC Section R408, UBC Section 2306.7, BNBC Section 1210.2 or SBC Section 1804.6.3.1, as applicable.
- Combustion air is provided in accordance with IMC (*International Mechanical Code*) Sections 701 and 703.

4.5 Exterior Finish:

4.5.1 Above Grade: The exterior surface of the ICF must be covered with an approved wall covering in accordance with the applicable code or a current evaluation report. Under the IRC, the wall openings must be flashed in accordance with IRC Section R703.8.

When the wall covering is required to be attached to structural members, the wall covering must be attached to the flanges of the plastic cross-ties with fasteners

described in Table 2 of this report of sufficient length to penetrate through the cross-tie flanges a minimum of $\frac{1}{4}$ inch (6.4 mm). The screws have an allowable withdrawal and lateral capacity as noted in Table 2. Screws may be placed into the BuildBlock (BB) flange hard point areas for additional fastening withdrawal and lateral capacities as noted in Table 2. The flange hard point area is described as a double-reinforced section of the flange located every 8 inches vertically (203 mm) on center and every 6 inches horizontally (152 mm) on center.

The maximum fastener spacing must be designed to support the gravity loads of the wall covering and resist the negative wind pressures. The negative wind pressure capacity of the exterior finish material must be the same as that recognized in the applicable code for generic materials, or that recognized in a current ICC-ES evaluation report for proprietary materials and must not exceed the rated maximum withdrawal rating of the screws.

4.5.2 Below Grade: Materials used to dampproof or waterproof basement walls must be specified by BuildBlock Building Systems, LLC, and must comply with the applicable code or a current evaluation report. The materials must be compatible with the ICF foam plastic units and be free of solvents, hydrocarbons, ketones and esters that will adversely affect the EPS foam plastic panels. Dampproofing, waterproofing and drainage requirements must comply with the applicable code. No backfill can be applied against the wall until the complete floor system is in place, unless the wall is designed as a freestanding wall that does not rely on the floor system for structural support.

4.6 Foundation Walls:

The ICFs are permitted to be used as a foundation stem wall when supporting wood-framed or steel-framed construction, provided the structure is supported on concrete footings complying with the applicable code. For jurisdictions adopting the IRC, compliance with Section R404 is required; for jurisdictions adopting the SBC, compliance with Section 1804.6.2 is required; for jurisdictions adopting the IOTFDC, compliance with Section 404 is required. Compliance with UBC Table 18-I-C is mandatory in jurisdictions adopting the UBC.

4.7 Retaining Walls:

The ICFs are permitted to be used as a retaining wall with reinforcement designed in accordance with accepted engineering principles, Section 4.2 of this report, and the applicable code.

4.8 Protection Against Termites:

In jurisdictions that have adopted the IBC, IRC, SBC or IOTFDC, where the probability of termite infestation is defined as “very heavy” by the code official, the foam plastic must be installed in accordance with IBC Section 2603.8, Section R320.5 of the IRC, Sections 1916.7.5 and 2603.3 of the SBC, or Section R323.4 of the IOTFDC, as applicable. Areas of very heavy termite infestation must be determined in accordance with Figure R301.2(6) of the IRC, Figure 2304.1.4 of the SBC and Figure 301.2(6) of the IOTFDC, as applicable.

4.9 Fire-resistance-rated Construction:

The ICFs may be used to construct load-bearing and non-load-bearing fire-resistance-rated wall assemblies as shown in Table 1.

4.10 Type I, II, III and IV (Noncombustible) Construction:

For the purposes of this report, noncombustible construction is defined as Type I, II, III or IV under the IBC, Types 1, 2, 3 or 4 under the BNBC, Types I, II, III or IV under the SBC, and Types I and II under the UBC. The ICFs are recognized for use in buildings of noncombustible construction provided the ICFs are used to form solid concrete walls and comply with the following:

4.10.1 Exterior Walls of Buildings of Any Height: The walls must have an exterior wall covering complying with Section 4.11.1.1, 4.11.1.2 or 4.11.1.3; an interior wall covering complying with Section 4.11.1.4; and must have fire-blocking complying with Section 4.11.1.5.

4.10.1.1 EIFS and One-Coat Stucco—Exterior Finish: The following EIFS or one-coat stucco lamina is permitted to be installed over the exterior of the forms using the reinforcing fabric or lath, base coat and finish coat materials described in their evaluation report: BASF Corporation, Senerflex EIFS as described in [ESR-1794](#).

4.10.1.2 Brick Veneer—Exterior Finish: Anchored brick veneer must be attached to the flanges of the plastic cross-ties with fasteners as described in Section 4.5.1 of this report. The 4-inch-thick (102 mm) brick veneer must comply with the applicable code and must be installed with a minimum 1-inch (25.4 mm) air gap between the face of the exterior EPS panel and the brick. The brick must be installed with a steel shelf angle attached to the concrete and installed at each floor line and at the top of each window and door opening. The brick ledge block is acceptable for use in one- and two-story buildings.

4.10.1.3 Brick Veneer—Exterior Finish: Anchored brick veneer must be attached to the flanges of the plastic cross-ties with fasteners as described in Section 4.5.1 of this report. The 4-inch-thick (102 mm) brick veneer must comply with the applicable code and must be installed with a minimum 1-inch (25.4 mm) air gap between the face of the exterior EPS panel and the brick. The brick must be installed with a steel shelf angle attached to the concrete and installed at each floor line and at the top of each window and door opening. The brick ledge block is acceptable for use in one- and two-story buildings.

4.10.1.4 Interior Finish: The forms must be finished on the interior with an approved 15-minute thermal barrier, such as $\frac{1}{2}$ -inch-thick (12.7 mm) gypsum board, as required by the applicable code. The gypsum board must be installed and attached as described in Section 4.4.1.

4.10.1.5 Fireblocking: For applications on buildings of any height, floor-to-wall intersections must be fireblocked in accordance with the applicable code to prevent the passage of flame, smoke and hot gases from one story to another. The foam plastic insulation on the interior side of the exterior walls and on both sides of interior walls must be removed so it is not continuous from one story to another. See Figure 4 for typical details.

4.10.2 Exterior Walls of One-story Buildings:

4.10.2.1 Fire Sprinklers: The building must be equipped throughout with an automatic sprinkler system in accordance with the applicable code.

4.10.2.2 Exterior Finish: The exterior of the foam plastic panels must be covered with aluminum of a thickness of not less than 0.019 inch (0.48 mm), or corrosion-resistant steel having a base-metal thickness of 0.016 inch (0.41 mm). Attachment of the metal wall covering must be designed by a registered design professional.

4.10.2.3 Interior Finish: The forms must be finished on the interior with an approved 15-minute thermal barrier such as 1/2-inch-thick (12.7 mm) gypsum board, as required by the applicable code. The gypsum board must be installed and attached as described in Section 4.4.

4.11 Special Inspection:

4.11.1 IBC: Special inspection is required as noted in IBC Section 1704 for placement of reinforcing steel and concrete, and for concrete cylinder testing. Special inspection, in accordance with IBC Sections 1704.1 and 1704.12, is required when an EIFS wall covering is applied. Duties of the special inspector must include verifying field preparation of materials, expiration dates, installation of components, curing of components, and installation of joints and sealants.

4.11.2 IRC: For walls designed and constructed in accordance with Section 4.2.3 of this report, special inspection is not required. For walls designed in accordance with Section 4.2.4, special inspection in accordance with Section 4.11.1 of this report is required.

4.11.3 UBC: Special inspection is required in accordance with UBC Section 1701 for placement of reinforcing steel and concrete, and for concrete cylinder testing. When approved by the code official, special inspection may be waived when all the following conditions are met:

- Walls are a maximum of 8 feet (2.4 m) high, and are limited to use in single-story construction of Group R, Division 3, or Group U, Division 1, Occupancies.
- Maximum height of a concrete pour is 48 inches (1219 mm). Succeeding lifts must be placed in accordance with UBC Section 1905.10.5.
- Installation is by installers acceptable to BuildBlock Building Systems, LLC.
- Half the allowable stresses or loads permitted by the UBC are used for the design of the walls.
- Installation instructions indicate methods used to verify proper placement of concrete.

4.11.4 BNBC: Special inspection is required as noted in BNBC Section 1705.4, and must include, but must not be limited to: verification of material specifications for concrete, reinforcing steel and formwork materials; installation of reinforcing steel; formwork installation; bracing; and concreting operations.

4.11.5 SBC: Special inspection is required as noted in SBC Section 1707.1, and must include, but must not be limited to: verification of material specifications for concrete, reinforcing steel and formwork materials; installation of reinforcing steel; formwork installation; bracing; and concreting operations.

5.0 CONDITIONS OF USE

The BuildBlock Insulating Concrete Forms (ICFs) described in this report comply with, or are suitable alternatives to what is specified in, those codes listed in Section 1 of this report, subject to the following conditions:

5.1 Form units are manufactured, identified and installed in accordance with this report and the BuildBlock® Insulating Concrete Forms published installation instructions. If there is a conflict between the manufacturer's published installation instructions and this report, this report governs.

5.2 Form units must be separated from the building interior with an approved 15-minute thermal barrier, except for crawl space construction as described in Section 4.4.2.

5.3 BuildBlock Building Systems, LLC, forms are limited to buildings of combustible construction [Type V-B (IBC), Type V-N (UBC), Type 5B (BNBC) and Type VI (SBC)], and buildings under the IRC or IOTFDC], except as described in Section 4.10

5.4 When used in buildings required to be of noncombustible construction, as described in Section 4.4, the forms must have at least one label as described in Section 7.0 visible in every 160 square feet (14.7 m²) of wall area, prior to the application of the wall covering.

5.5 The use of 4-inch BuildBlock ICFs is limited to above-grade construction in accordance with IRC Section R611.

5.6 Calculations showing compliance with the general design requirements of the applicable code must be submitted to the code official for approval, except that calculations are not required when the building design is based on Section 4.2.3 of this report. The calculations and details must be prepared by a registered design professional where required by the statutes of the jurisdiction in which the project is to be constructed.

5.7 Special inspection must be provided in accordance with Section 4.11.

5.8 When use is as part of a fire-resistance-rated assembly, Section 4.9 applies.

5.9 BuildBlock Building Systems, LLC, forms are manufactured in Pardeeville, Wisconsin; Colorado Springs, Colorado; Elkhart, Indiana; West Brookfield, Massachusetts; Nixa, Missouri; Orlando, Florida; McFarland, California; and Post Falls, Idaho, under quality control programs with inspections conducted by Intertek Testing Services NA, Ltd. (AA-690).

6.0 EVIDENCE SUBMITTED

Data in accordance with the ICC-ES Acceptance Criteria for Stay-in-place Foam Plastic Insulating Concrete Form (ICF) Systems for Solid Concrete Walls (AC353), dated October 2007 (editorially revised April 2008).

7.0 IDENTIFICATION

Each package or pallet of BuildBlock® Insulating Concrete Forms must be labeled with the company name (BuildBlock Building Systems, LLC), address and telephone number; manufacturing location and date; the lot number and the name of the inspection agency (Intertek Testing Services NA Ltd.); and the evaluation report number (ESR-1911).

Additionally, when use is in buildings required to be of noncombustible construction, one label on the form unit as described in this section must be visible in every 160 square feet (14.7 m²) of wall area.

TABLE 1—THREE HOUR FIRE-RESISTANCE-RATED WALL ASSEMBLIES⁴

WALL TYPE	FORM WIDTH (inches)	INTERIOR WALL FINISH ^{3,4}	STEEL REINFORCEMENT ¹ (minimum)
Bearing - ^{1,2,3,4,5} Max. load 5000 lbf/lin ft	13	1/2-inch gypsum wall board fastened 12 inches o.c. in field and 6 inches o.c. at perimeter	Vertical - #5, 24 inches o.c. Horizontal - #5, 32 inches o.c.
Bearing - ^{1,2,3,4,5} Max load 5000 lbf/lin ft	11	1/2-inch gypsum wall board fastened 12 inches o.c. in field and 6 inches o.c. at perimeter	Vertical - #5, 24 inches o.c. Horizontal - #5, 32 inches o.c.
Nonbearing - ^{2,3}	13	1/2-inch gypsum wall board fastened 12 inches o.c. in field and 6 inches o.c. horz. at perimeter	Vertical - #5, 24 inches o.c. Horizontal - #5, 32 inches o.c.
Nonbearing - ^{2,3}	11	1/2-inch gypsum wall board fastened 12 inches o.c. in field and 6 inches o.c. horz. at perimeter	Vertical - #5, 24 inches o.c. Horizontal - #5, 32 inches o.c.

For **SI**: 1 inch = 25.4 mm, 1 lbf/ft = 14.59 N/m.

¹Steel reinforcement is the minimum required for the design loads given.

²Concrete must be normal-weight concrete [(150-155 lb/ft³) (2403-2483 kg/m³)] with a minimum 3000 psi (20 684 kPa) compressive strength.

³See Section 4.4 for type of fastener.

⁴The wall assembly may be used as either an interior or exterior wall. When used as an interior wall, both sides of the form must be protected with the interior gypsum board as noted in the table.

⁵Design loads are based on 10-foot wall heights.

TABLE 2—ALLOWABLE WITHDRAWAL AND LATERAL CAPACITIES OF FASTENERS IN CROSS-TIE FLANGES

FASTENER ¹	ALLOWABLE LOAD CAPACITY (lbf)	
	Lateral	Withdrawal
#2 Square drive, 0.120-inch, fine thread screw having average of 5 threads per inch placed at any point on the web ties fastening flange	56	24
#2 Square drive, 0.120-inch, fine thread screw having average of 15 threads per inch placed at center of BB Hard Point ¹ location of the web tie	33	56
No. 6, Type S, fine thread drywall screw placed at any point on the web ties fastening flange	54	31
No. 6, Type S, fine thread drywall screw placed at center of BB Hard Point ² location of the web tie	81	66

For **SI**: 1 pound = 4.45 N, 1 inch = 25.4 mm.

¹Fasteners must be of sufficient length to penetrate through the web-tie flange a minimum of 1/4 inch (6.2 mm).

²BB Hard Point locations are double-flanged reinforced sections in the flange of the cross-tie located every 8 inches on center vertically and every 6 inches on center horizontally.

STRAIGHT BLOCK

DIMENSIONS (IMPERIAL)	FORM SIZE (CORE)		
	4"	6"	8"
A	4'-0"	4'-0"	4'-0"
B	9"	11"	1'-1"
C			
D1	1'-4 1/2"	1'-4 1/2"	1'-4 1/2"
D2	3 1/4"	3 1/4"	3 1/4"
D3	3 1/2"	3 1/2"	3 1/2"
D4	7"	7"	7"
D5	7 3/4"	7 3/4"	7 3/4"
D6	3 3/4"	3 3/4"	3 3/4"
D7	4"	4"	4"
D8	1"	1"	1"
E	4"	6"	8"
E2	7/8"	7/8"	7/8"
E3	3/4"	3/4"	3/4"
F	8 1/4"	8 1/4"	8 1/4"
G	8"	8"	8"
H	4 1/4"	4 1/4"	4 1/4"
J	1'-3 1/2"	1'-3 1/2"	1'-3 1/2"
K	1/2"	1/2"	1/2"
L	2 1/2"	2 1/2"	2 1/2"
M1	1 3/8"	1 3/8"	1 3/8"
M2	1 1/8"	1 1/8"	1 1/8"
O	3/16"	3/16"	3/16"
Q	6"	6"	6"
R	3"	3"	3"

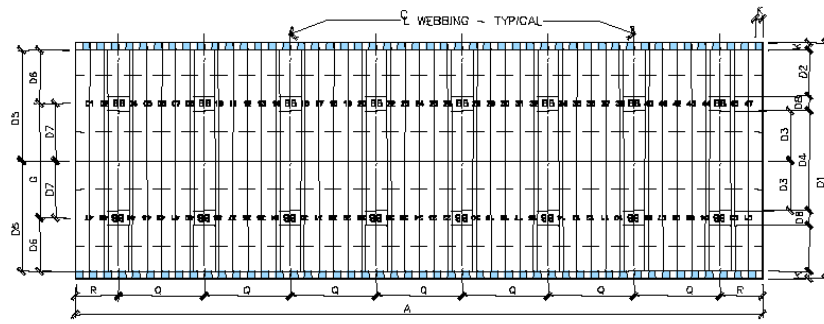

LEGEND
 □ = POSITIVE PROFILES (TOUNGES)
 □ = 1/2 HEIGHT POSITIVE PROFILES (BASELINE)
 □ = NEGATIVE PROFILES (GROOVES)

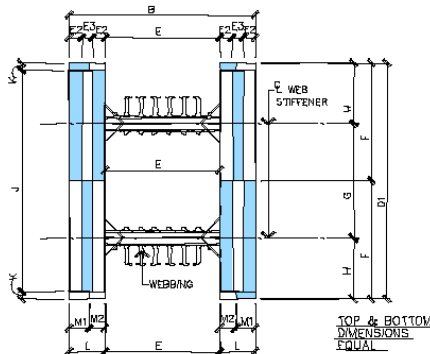
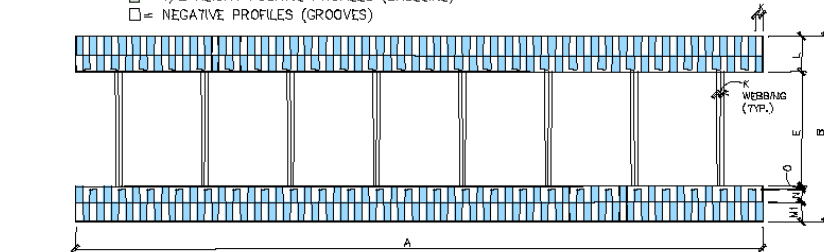

SIDE VIEW

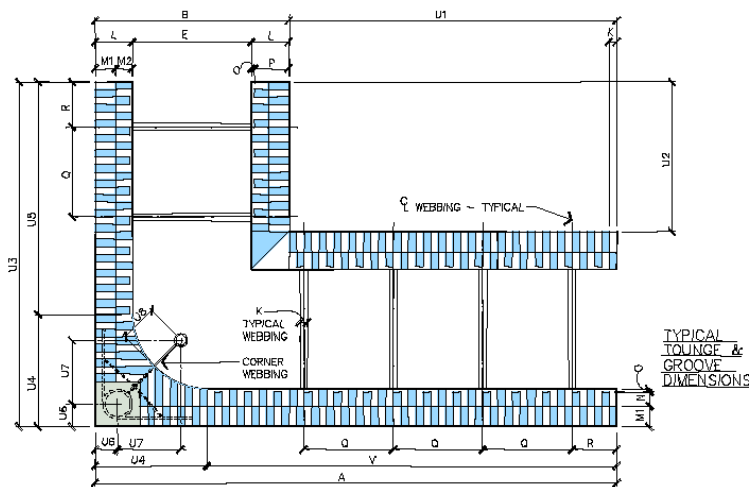

TOP / BOTTOM VIEW

90° REVERSIBLE CORNER

DIMENSIONS (IMPERIAL)	FORM SIZE (CORE)		
	4"	6"	8"
A	2'-7"	2'-9"	2'-11"
B	9"	11"	1'-1"
E	4"	6"	8"
K	1/2"	1/2"	1/2"
L	2 1/2"	2 1/2"	2 1/2"
M1	1 3/8"	1 3/8"	1 3/8"
N	15/16"	15/16"	15/16"
O	3/16"	3/16"	3/16"
P	2 5/16"	2 5/16"	2 5/16"
Q	6"	6"	6"
R	3"	3"	3"
U1	1'-10"	1'-10"	1'-10"
U2	10"	10"	10"
U3	1'-7"	1'-9"	1'-11"
U4	7 1/2"	7 1/2"	7 1/2"
U5	17 1/2"	1'-1 1/2"	1'-3 1/2"
U6	1 1/2"	1 1/2"	1 1/2"
U7	4 1/4"	4 1/4"	4 1/4"
U8	2 1/2"	2 1/2"	2 1/2"
V	1'-11 1/2"	2'-1 1/2"	2'-3 1/2"

FIGURE 1—BUILDBLOCK® FORMS

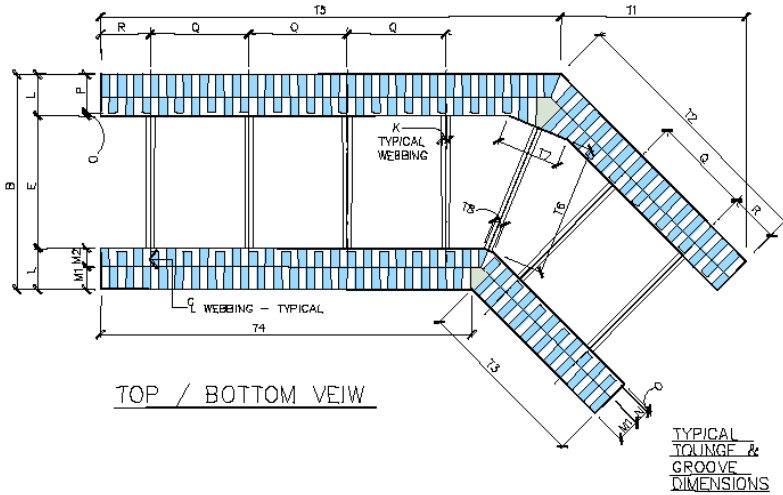

45° REVERSIBLE CORNER

DIMENSIONS (IMPERIAL)	FORM SIZE (CORE)		
	4"	6"	8"
A			
B	9"	11"	1'-1"
E	4"	6"	8"
K	1/2"	1/2"	1/2"
L	2 1/2"	2 1/2"	2 1/2"
M1	1 3/8"	1 3/8"	1 3/8"
M2	1 1/8"	1 1/8"	1 1/8"
N	15/16"	15/16"	15/16"
O	3/16"	3/16"	3/16"
P	2 5/16"	2 5/16"	2 5/16"
Q	6"	6"	6"
R	3"	3"	3"
T1	11 5/16"	11 5/16"	11 5/16"
T2	1'-4"	1'-4"	1'-4"
T3	1'-0 9/32"	11 7/16"	10 5/8"
T4	2'-0 9/32"	1'-11 7/16"	1'-10 5/8"
T5	2'-4"	2'-4"	2'-4"
T6	4"	6"	8"
T7	3 1/16"	3 1/16"	3 7/8"
T8	11/16"	11/16"	11/16"

8 LEDGE BLOCK

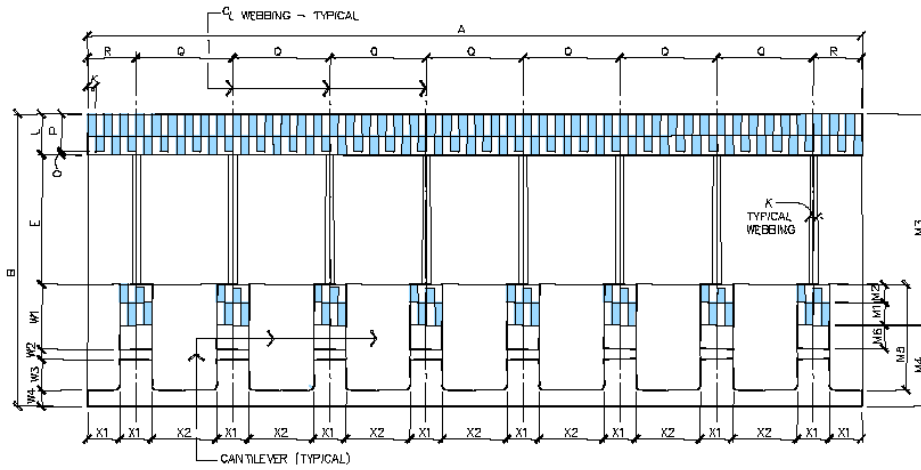

LEDGE BLOCK

DIMENSIONS (IMPERIAL)	FORM SIZE (CORE)	
	6"	8"
A	4'-0"	4'-0"
B	1'-4"	1'-6"
C	11"	1'-1"
D	1'-4 1/2"	1'-4 1/2"
E	6"	6"
E2	7/8"	7/8"
E3	3/4"	3/4"
F	8 1/4"	8 1/4"
G	8"	8"
H	4 1/4"	4 1/4"
K	1/2"	1/2"
L	2 1/2"	2 1/2"
M1	1 3/8"	1 3/8"
M2	1 1/8"	1 1/8"
M3	11"	1'-1"
M4	5"	5"
M5	6 1/2"	6 1/2"
M6	1 7/16"	1 7/16"
O	3/16"	3/16"
P	2 5/16"	2 5/16"
Q	6"	6"
R	3"	3"
W1	4"	4"
W2	5/8"	5/8"
W3	1 7/8"	1 7/8"
W4	1"	1"
W5	3 3/16"	3 3/16"
X1	2"	2"
X2	4"	4"
Y1	5 3/4"	5 3/4"
Y2	9 1/2"	9 1/2"
Y3	1"	1"
Y4	10 3/8"	10 5/8"
Y5	2 3/4"	2 3/4"
Y6	2 3/16"	2 3/16"
Z1	1/4"	1/4"
Z2	1 7/8"	1 7/8"
Z3	2"	2"

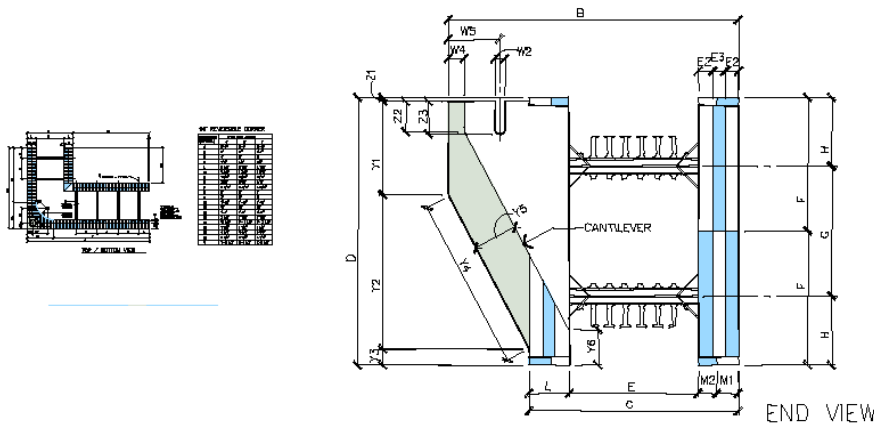

FIGURE 1—BUILDBLOCK® FORMS (Continued)

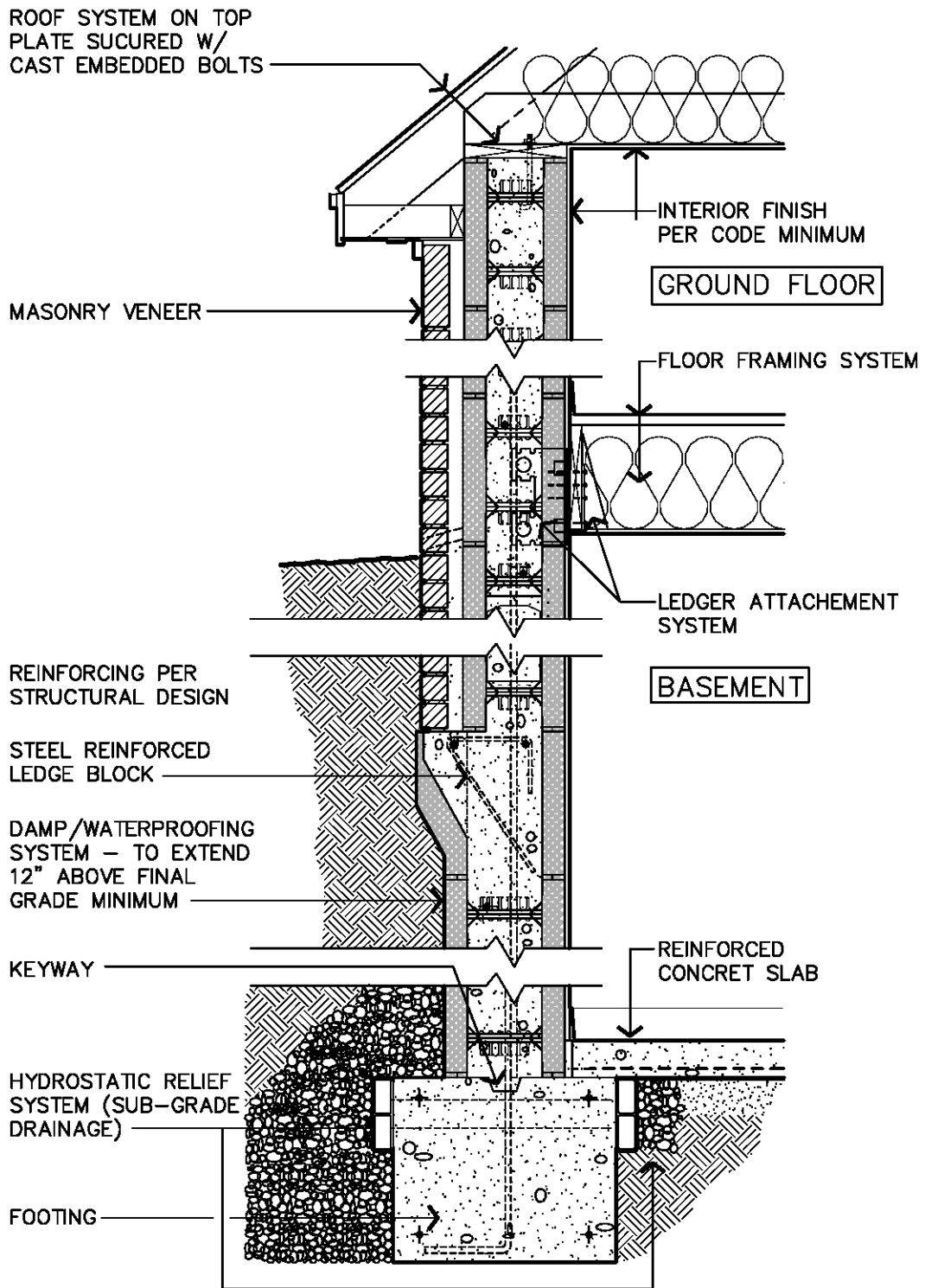

FIGURE 2—BUILDBLOCK® BASEMENT WALL DETAIL

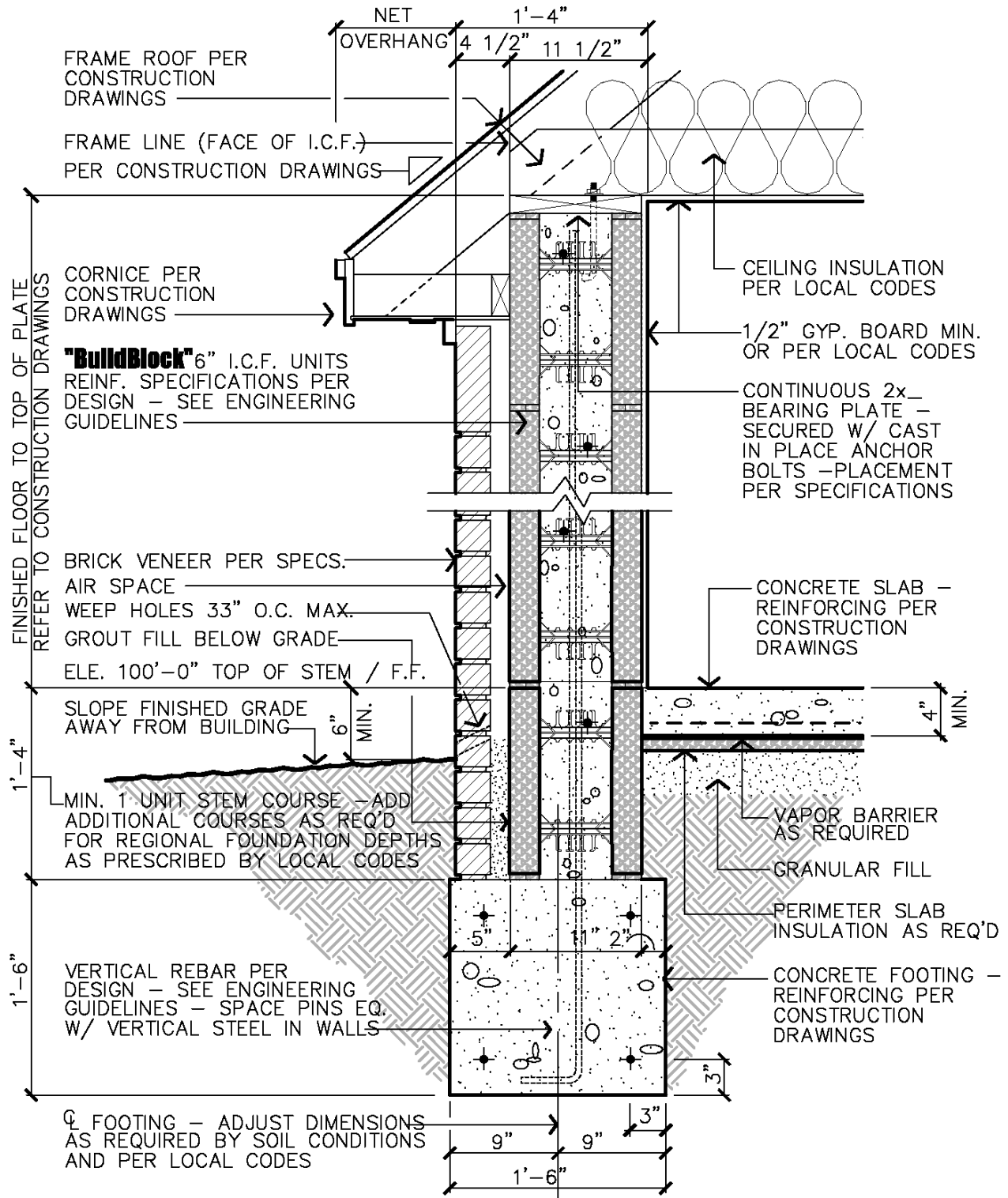

FIGURE 3—BUILDBLOCK® SINGLE STORY WALL DETAIL

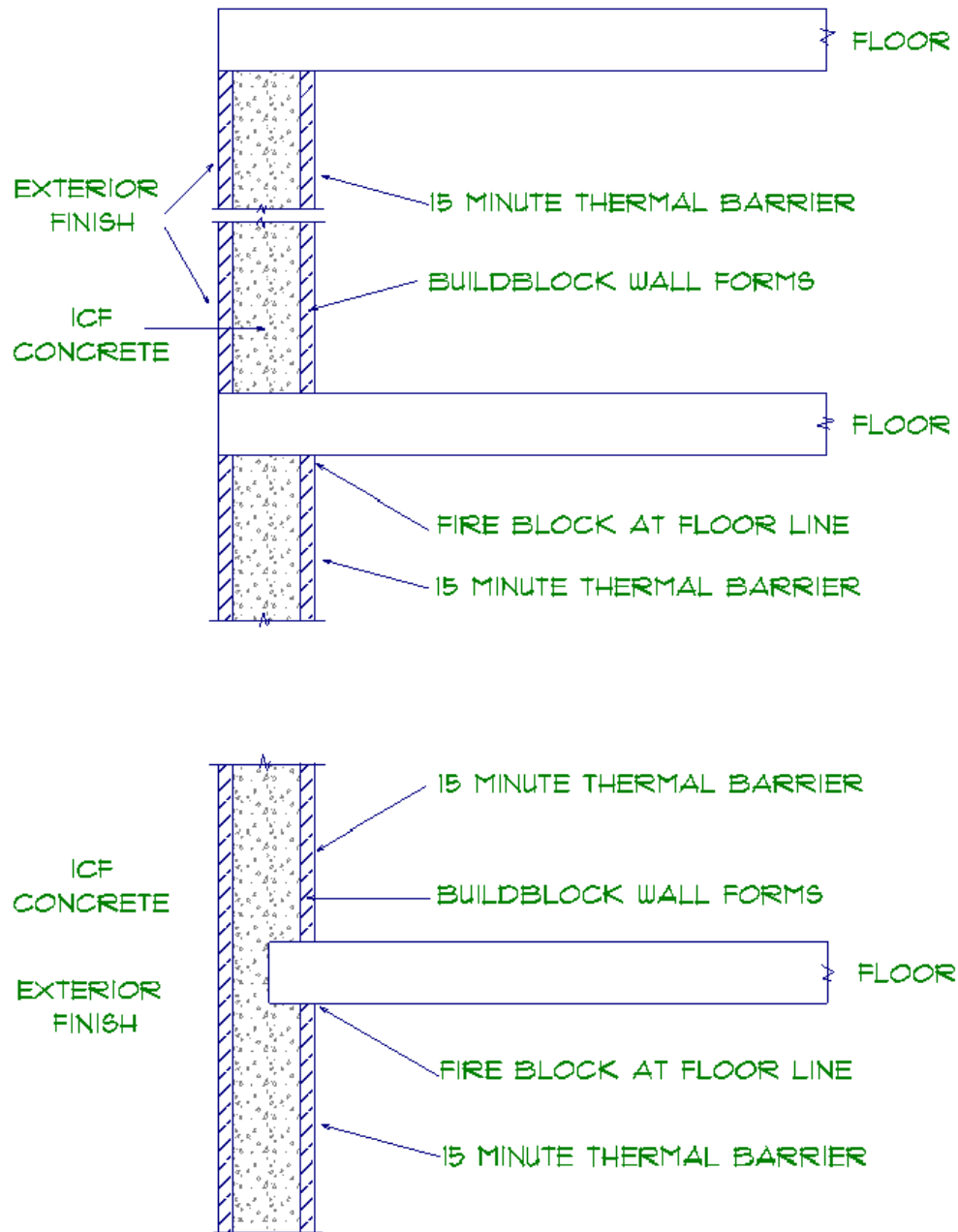

FIGURE 4—BUILDBLOCK® TYPICAL WALL DETAIL FOR NON COMBUSTIBLE CONSTRUCTION

ICC-ES Evaluation Report**ESR-1911 Supplement**

Issued March 1, 2011

This report is subject to renewal on September 1, 2012.

www.icc-es.org | (800) 423-6587 | (562) 699-0543 A Subsidiary of the International Code Council®

DIVISION: 03 00 00—CONCRETE
Section: 03 11 19—Insulating Concrete Forming

REPORT HOLDER:

BUILDBLOCK BUILDING SYSTEMS, LLC
9705 NORTH BROADWAY EXT., SUITE 200
OKLAHOMA CITY, OKLAHOMA 73114
(405) 840-3386
www.buildblock.com

EVALUATION SUBJECT:**BUILDBLOCK® INSULATING CONCRETE FORMS (ICFs)****1.0 EVALUATION SCOPE****Compliance with the following codes:**

- 2007 Florida Building Code—Building
- 2007 Florida Building Code—Residential

Properties evaluated:

- Structural
- Surface-burning characteristics
- Crawl space fire evaluation
- Fire-resistance-rated construction
- Noncombustible construction

2.0 PURPOSE OF THIS SUPPLEMENT

This supplement is issued to indicate that the BuildBlock® Insulating Concrete forms (ICFs) described in Sections 2.0 through 7.0 of the master report comply with the 2007 Florida Building Code—Building and the 2007 Florida Building Code—Residential, when designed and installed in accordance with the master evaluation report.

Use of the BuildBlock® ICFs as described in the master evaluation report to comply with the High Velocity Hurricane Zone Provisions of the 2007 Florida Building Code—Building and the 2007 Florida Building Code—Residential has not been evaluated and is outside the scope of this supplement.

For products falling under Florida Rule 9N-3, verification that the report holder's quality assurance program is audited by a quality assurance entity approved by the Florida Building Commission for the type of inspections being conducted is the responsibility of an approved validation entity (or the code official when the report holder does not possess an approval by the Commission).

This supplement expires concurrently with the master report reissued on September 1, 2010.