

THE STRONGEST LOCKING WEB BRIDGE IN THE INDUSTRY

The **BuildLock™** System is a high performance knock-down insulating concrete form (ICF) wall system comprised of two separate 2 ½ inch Expanded Polystyrene (EPS) panels which are connected by strong, high-density plastic webs on 6-inch centers. **BuildLock™** is the strongest knock-down product on the market today. Each web bridge features a positive locking attachment that snaps the web securely in the proper position to eliminate racking and provide superior structural stability throughout the construction process.



Why BuildLock

- Available in 8", 10" and 12" core widths with 4" and 6" core widths coming soon
- BuildLock's patented web provides superior strength
- Double-reinforced corner webs on 10" and 12" forms
- Expandable core for larger sizes with optional bridge connector
- Reduce shipping costs by up to 50%
- Increase product storage capacity
- Larger rebar saddles for multiple rebar sizes
- Reinforced web flanges for additional strength
- Simple, quick on-site assembly
- Completely reversible webs for multiple rebar locations



Knock-Down BLOCK

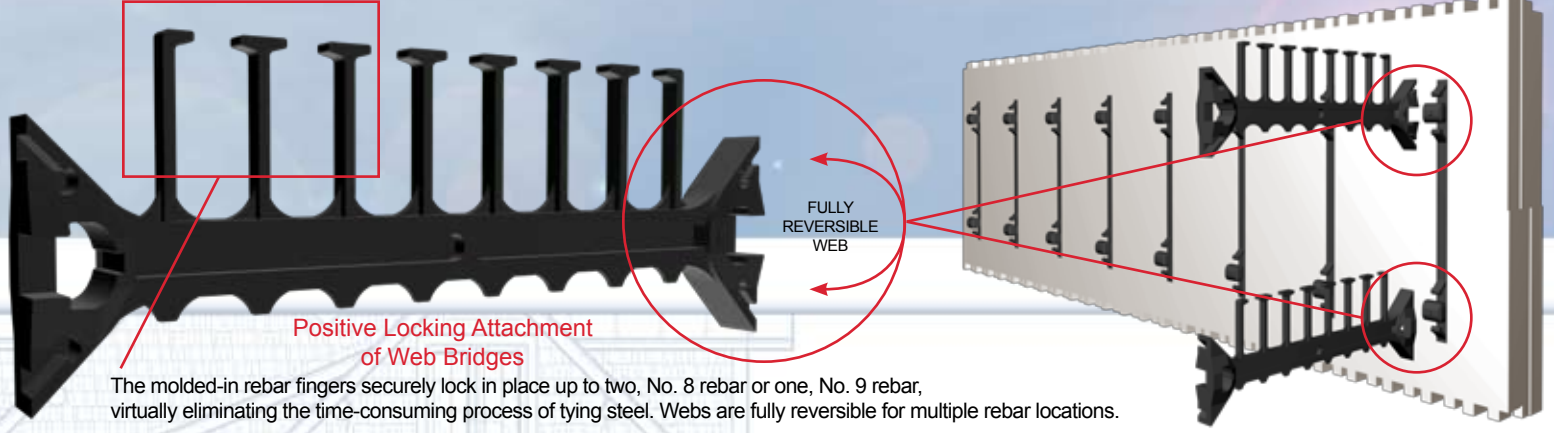

BuildLock™ Best Corner Web on the Market

Reversible. Use corners for left or right stacking.

Longer. Extra length in both directions eliminates the need for additional strapping during installation and concrete pour saving time and labor. Many additional furring attachment points.

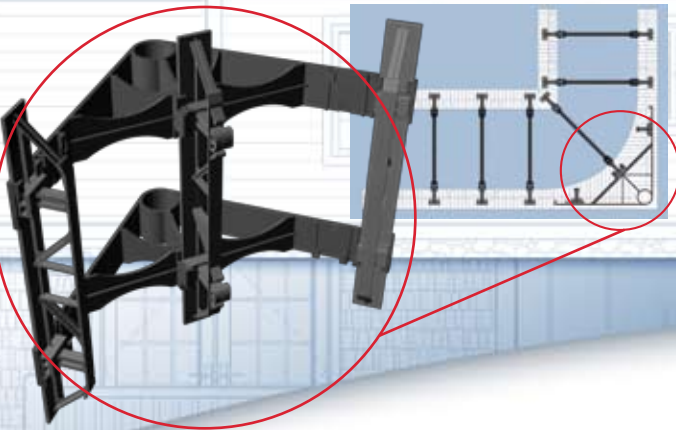

BuildLock	Width	Length	Return	Area	Con. Vol.
8" Concrete Core	13"	48"	N/A	5.33 sq.ft.	0.131687
10" Concrete Core	15"	48"	N/A	5.33 sq.ft.	0.164609
12" Concrete Core	17"	48"	N/A	5.33 sq.ft.	0.197529
10" 90° Corner	15"	37" (ext.) 22" (int.)	25" (ext.) 10" (int.)	6.88 sq.ft.	0.151444
12" 90° Corner	17"	39" (ext.) 22" (int.)	27" (ext.) 10" (int.)	7.33 sq.ft.	0.191408

Features on all BuildBlock products include:

- Webs on 6-inch centers
- Fully reversible blocks and webs
- Numbered and marked 1" cut lines
- Molded-in horizontal cut lines every 2 inches
- Strong interlocking connectors
- Easy electrical and plumbing installation
- Form and insulate in one step
- Allows for any finish application
- Lowers sound transmission
- Contributes to high thermal insulation values resulting in reduced energy costs
- All BuildBlock products meet or exceed industry standards

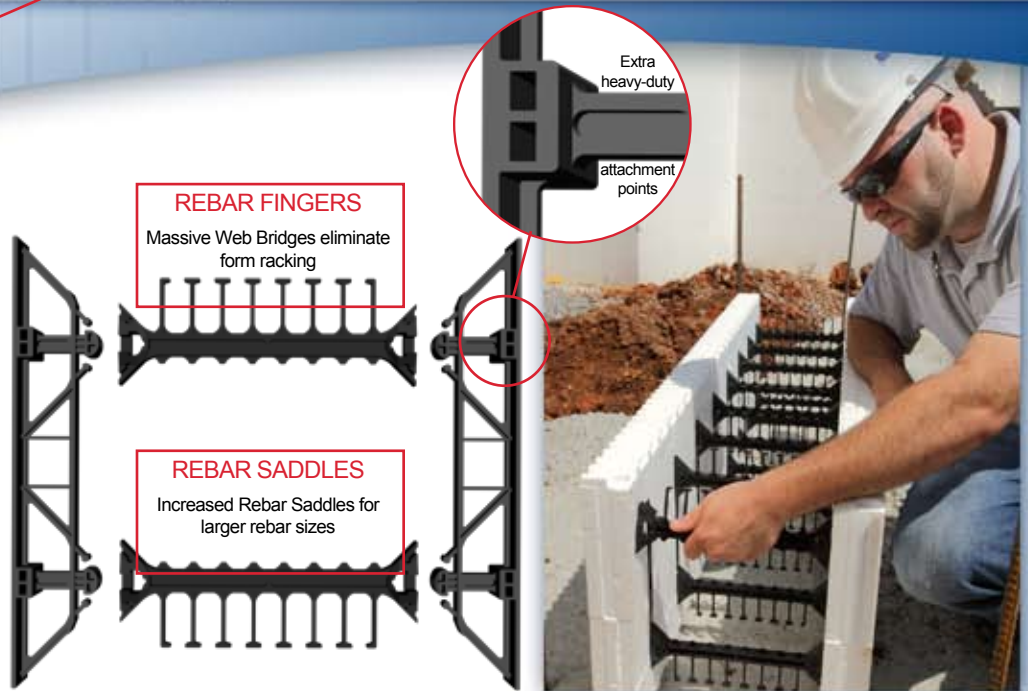

The webs also serve as furring strips for interior and exterior finishes with a pull-out strength of 150 lbs. These furring strips include hard points with a pull-out strength of about 500 lbs. and are easily identified by molded-in markings on both sides of the form.

BuildBlock® product line:

BuildBlock® offers a comprehensive product line that will complete the envelope of nearly any residential or commercial structure. Products include fully-assembled insulating concrete forms, BuildLock knock-down product line, and BuildDeck floor and roof system.

